

EM-32 Electronic Room Responsive Controller

Application

The electronic room controller will manage temperature in a single area or if placed in the correct location a complete system. The placement of the wall unit is critical to the performance of the system. Ideally the wall unit is mounted on an interior wall. Placing the wall unit near fireplaces, aggressive lighting or passive solar areas can have a unsatisfactory result in performance. If this is the case, then selection of another device to control your system should be made. The theory behind this control is that with proper placement the wall unit will sense the correct temperature transmission leaving the residence and correct itself accordingly to maintain a very stable temperature environment. With today's well insulated homes, interior room temperature sensing provides a high degree of comfort and excellent energy conservation characteristics. This control will also manage a high temperature system with the same advantages of a floor heating system, but with the added ability to reduce temperature setting in unoccupied or during sleeping times. It will also respond with a heating optimization feature to keep the temperature consistent when coming out of night setback.

Operation

The Electronic Room Responsive Control (EM-32) is a modulating diverting valve control. The closer the room temperature gets to the set point of the thermostat, the lower the system water temperature will be.

When the set-point is reached, the diverting valve will recirculate 100% of the system return water, assuring constant circulation at all times. The 20°C adjustment on the thermostat represents 68°F room temperature.

Temperature range is in Celsius.

The settings go from 50° F [10°C] to 86°F [40°C].

A floor heating system will normally only get to 77°F [25°C]

The graduation on the thermostat represent the following and each line represents a 1 (one) °F [.5°C] increase or decrease in temperature.

* - frost protection: valve opens when room temperature drops

below 42°F

10 °C = 50°F

16 °C = 60°F

20 °C = 68°F

24 °C = 75°F

28 °C = 82°F



Specifications

24 volt power supply with a 0-10 volt output from wall unit to 0-10v proportional actuator mounted on the mixing valve. The wall thermostat is a digital room thermostat for controlling radiant floor heating systems with our proportional actuators (# 5009). This proportional thermostat features a microprocessor and a 0-10 V outputs and provides excellent, high-precision control response. Temperature pre-selection is in one degree steps. If this control is used for high temperature systems the energy savings mode can be activated by connecting an external timer signal for reduced temperature operation. This feature is not recommended for radiant floor heating systems. Installation and connection is with the pre-mounting base on which the wall thermostat can be easily removed for additional installer adjustments at any time.

Temperature settings

With floor heating systems changing temperatures is a time and load dependent function. Response time is in direct relation to the type of system, mass of the radiant floor, and outdoor temperature conditions. With a dry system (staple up with plates or subfloor system) response time can be short. Large mass systems (concrete slab on grade or gypcrete) the response time can be slow. In any case, patience is the rule and turning the thermostat up and down rapidly will only cause the system to respond slower. If the setting is not to your liking our suggestion is to move the temperature setting up 1 (one) °F and wait 12-24 hours before adjusting again.

Installation

Mount the room sensor on an inside wall of the heated room approximately 5 feet from the floor. Do not place it near drafts or behind objects that will block natural circulation (curtains, doors, cabinets, etc.) Thread the actuator onto the valve and hand tighten. The circulation pump must be wired for constant circulation with seasonal shut down and start up. Worst case wire the pump with a summer/winter on/off switch.

Trouble Shooting

Increase the setting at the thermostat and make sure the pump is running and there is sufficient water temperature provided from the heat source. Turn the thermostat up to make sure the actuator opens, temperature in the system should rise. Reduce the thermostat setting and make sure the actuator closes, system temperature should reduce. If the system does not respond to changes in thermostat setting, check that the actuator is firmly screwed onto the valve. Also examine the wiring per the diagram included in the document to make sure the proper voltages are being delivered to the thermostat and the proportional actuator. The last check would be to remove the actuator and depress the pin on the valve, by depressing the pin, the system will now be in full by-pass which means no heat will enter the mixed loop. If you now release the pin, 100% boiler temperature will enter the mixed loop. If this step does not function properly, look for foreign matter inside of the mixing valve and also make sure there are no other hydraulic issues in the hydronic system putting pump head pressure on the supply side of the mixed loop. If this occurs then no boiler water will enter the mixed loop and you will need to install a by-pass between the supply and return to alleviate the head pressure. This is a common problem associated with primary/ secondary piping systems.

mount on inside wall of heated room 5ft off the floor

EM-32

RANCO

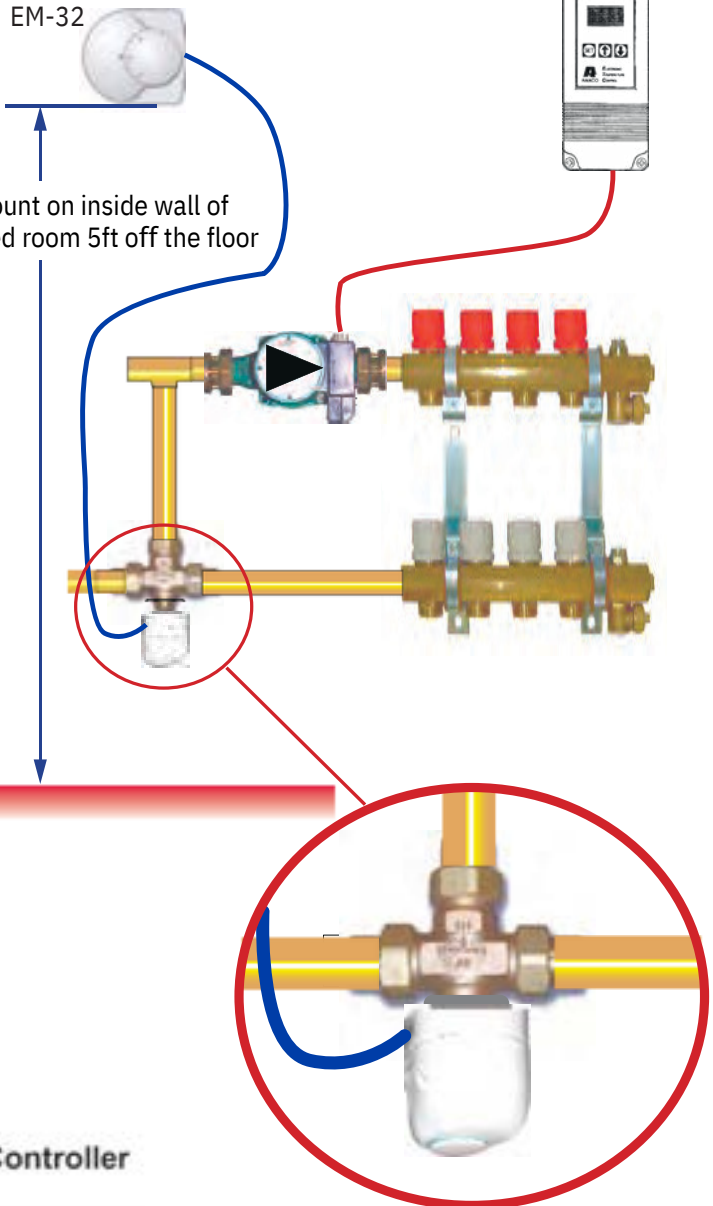

Technical Data

Type	EM-32 Room Responsive Controller
Version	Heating and cooling, 0-10 V each
Output characteristic	normal, inverse with jumpers
Contact rating per output	5 Alpha Actuators max. (Ri = 10 kOhm) 50 Alpha Actuators max. (Ri = 100 kOhm)
Operating voltage	24 V -20%...+45%, 50/60 Hz
Max. output current, each	5 mA at 10 V (short-circuit proof)
Economy mode	39°F [4°K] (fixed)
Neutral zone	adjustable from 0.5 K to 3 K
Control cycles	approx. 0.2 K with optimum of system dimensioning
Control range	50 to 82°F [10 to 28 °C]
Storage temperature	-13 to +158°F [-25 to +70 °C]
Ambient temperature	-13 to +104°F [-25 to +40 °C]
Relative humidity	80% max.
Degree / class of protection	IP 30 / II
CE conformity according to	EN 60730
Housing material	ABS
Weight	1.8 Oz [50 g] without Alpha-Mounting Base

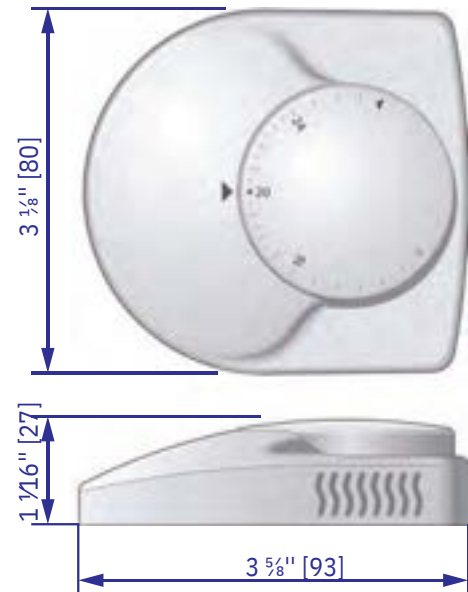

Electric Installation EM-32 ERRC

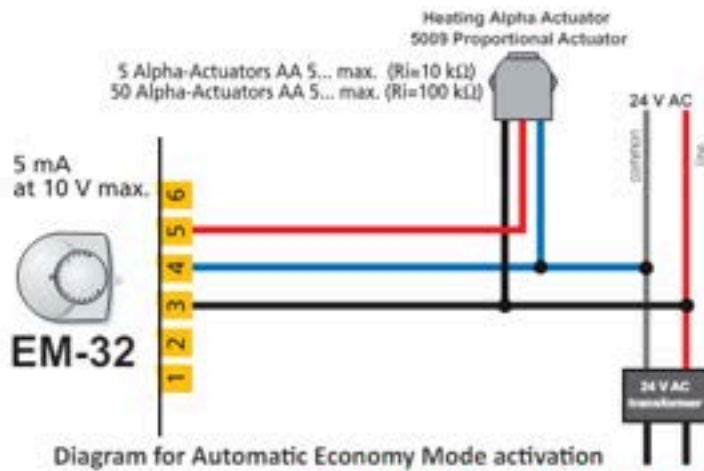

Wire configuration EM-32 ERRC

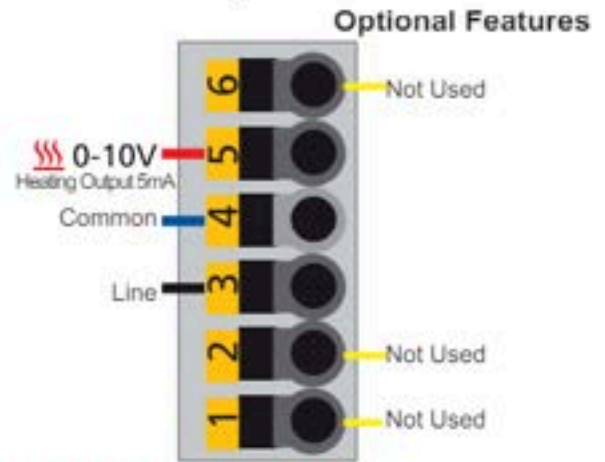

Note! Actuator must be powered for 6 minutes!

Note:

In order for the actuator (# 5009) to function properly it "must be installed" on a valve and powered for 6 minutes. Once the actuator "pop up button" is fully extended (approximately 1/4"), power must be removed allowing the actuator to completely reset. This takes approximately 10 minutes and you will notice that the "pop up button" is once again flush with the top of the actuator. This is a necessary step that must be taken to insure the actuator "learns" its travel limits with regards to the valve it is installed on. Also, make sure you "do not" apply power to the actuator before it is installed on a valve, this could cause the actuator to function improperly.



EM-32 Electronic Room Responsive Controller

The Hydronic Alternatives Electronic Room Responsive Controller (EM-32) provides room responsive water temperature control of a mixing valve for radiant floor heating systems.

The EM-32 Thermostat is a digital room thermostat for controlling heating and cooling applications equipped with proportional actuators (e.g. Alpha Actuator AA 5 ...). This proportional thermostat features a microprocessor and two separate 0-10 V outputs and offers excellent, high-precision control response. Temperature pre-selection is in 1/4 degree steps. The economy mode can be activated by connecting an external timer signal. The neutral zone where heating is not active can be adjusted from 1°F to 6°F.

Installation and connection is with the pre-installed AS 1000 Mounting Base on which this EM-32 Room Responsive Controller can be plugged at any time. To avoid damage to this high-class thermostat during the building phase, the system base may be installed in advance to carry out the necessary electric installation work.

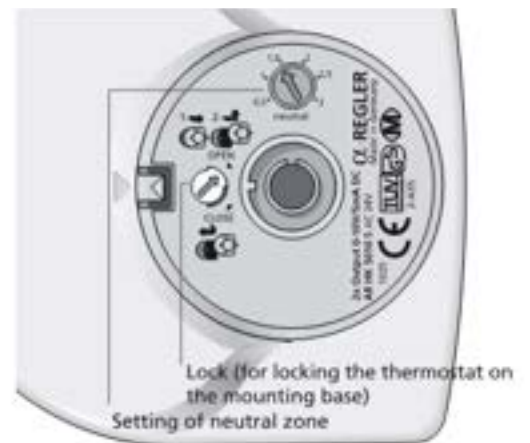

Features

The EM-32 Room Responsive Controller is an electronic modulating mixing valve controller. The wall unit modulates system water temperature via a 0-10 V DC proportional actuator to maintain a consistent room temperature setpoint by the user.

- Rotary temperature control with one degree soft clicks.
- Reduce night setback mode by external switching signal for high temperature heating only.
- Reverse output characteristic (10-0 V) by means of jumpers
- Control speed can be selected by means of jumpers
- High limit temperature setting.
- Precise control response
- Functional design

General Information

Type	EM-32 Room Responsive Controller
Housing Color	Standard Pure White
Scope of Supply	1 x EM-32 Room Responsive Controller 1 X Installation instructions 1 x Mounting Base
Ordering Information	Our staff will be glad to assist you in finding the EM-32 fitting your application

HA30D TWO STAGE ELECTRONIC TEMPERATURE CONTROL.

The HA30D is a microprocessor-based family of electronic temperature controls, designed to provide on/off control for commercial heating, cooling, air conditioning and refrigeration. The HA30D is equipped with a liquid crystal display (LCD) that provides a constant readout of the sensed temperature, and a touch keypad that allows the user to easily and accurately select the set point temperature, differential and heating/cooling mode of the operation. Models are available that operate on either line voltage (120/208/240 VAC) or low voltage (24VAC).



Installation Instructions HA30D

IMPORTANT

1. All HA30D series controls are designed as operating controls only. If an operating control failure could result in personal injury or loss of property, a separate safety control and/or alarm should be installed.
2. The schematic drawings and other information included in these installation instructions are for the purpose of illustration and general reference only.
3. These instructions do not expand, reduce, modify or alter the Terms in anyway; and no warranty or remedy in favor of the customer or any other person arises out of these instructions.
4. The HA30D controls have been approved by Underwriters' Laboratories as UL Listed; however, approval does not extend to their use for any other purpose. Hydronic Alternatives assumes no responsibility for any unconventional application of its control unless such application has been approved in writing by Hydronic Alternatives.
5. It is the responsibility of the installer and the user to assure that his or its application and use of all Hydronic Alternatives products are in compliance with all federal, state and local requirements, including, without any limitation, all requirements imposed under the National Electric Code and any applicable building codes.

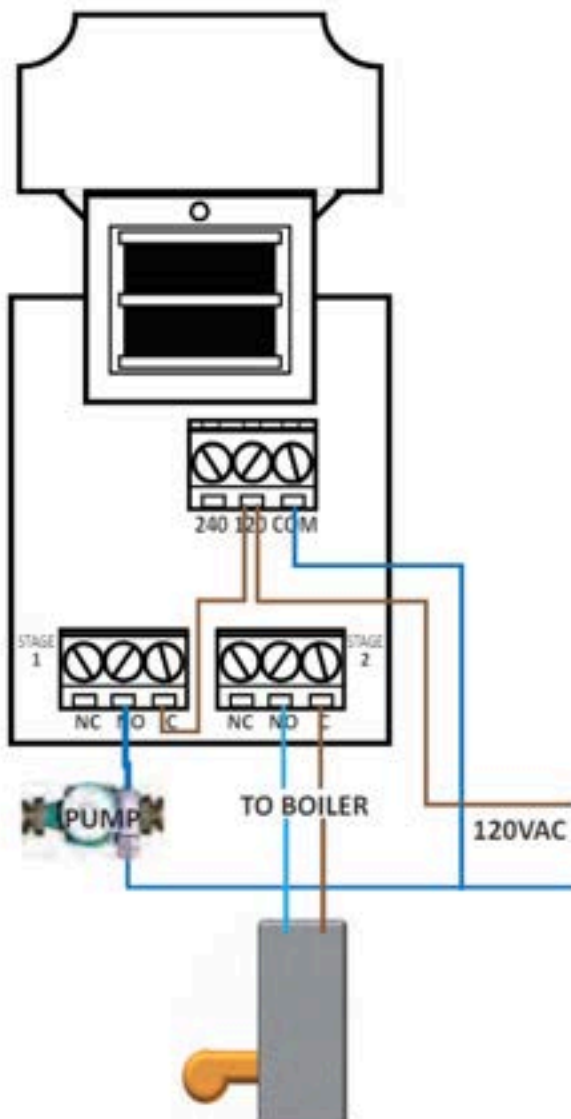

Line Voltage Wiring Diagram.

Electric Installation HA30D

General

- All wiring should conform to the National Electric Code and local regulations.
- The total electrical load must not exceed the maximum rating of the control (see Specifications).
- Use copper conductors only.
- Electrical leads should not be taut; allow slack for temperature change and vibration.

Input and Output Wiring

For typical wiring diagrams, refer to Figures 6 and 7.

All connections are made to the power (lower) circuit board. When using the 24 VAC powered models, the 24 VAC input lines must enter through the sidewall of the case. Refer to Figure 5 for location of the entry hole.

Analog Output





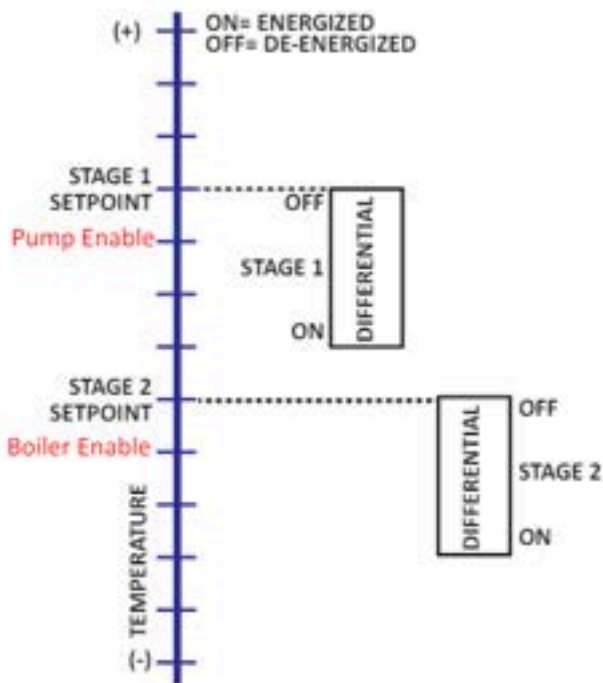

HA30D models are available with an optional 0 to 10 volt analog output. This signal is a linear representation of the sensor temperature with 0 volts = -30°F and 10 volts = 220°F. See figure 8 for wiring information and Figure 5 for location of the entry hole. The reference for this output is designated by the "-" symbol on the wiring diagram. The output signal is designated by the "+" symbol.

Sensor Wiring

The temperature sensor leads are soldered to the circuit board so no additional connections are necessary. However, splicing is required when extending the sensor cable length beyond the standard 8 foot length supplied with the HA30D. The sensor cable can be extended up to 400 feet. A damaged sensor can be replaced by splicing a new Ranco sensor onto the sensor leads from the circuit board. The sensor is not polarity sensitive.

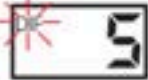
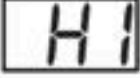

Two Stage Heating Example

Step	Annunciator	Description	Display
1	F or C	Fahrenheit or Celsius Scale	
2	S1 (blinking)	Stage 1 Set point emperature	
3	DIF1 (blinking)	Stage 1 Differential Temperature	
4	C1/H1	Stage 1 Heating Mode	
5	S2 (blinking)	Stage 2 Setpoint Temperature	
6	DIF (blinking)	2 Stage 2 Differential Temperature	
7	C2/H1-12	Stage 2 Heating Mode	

Programming Steps and Display

The HA30D two stage can be programmed in seven simple steps using the LCD display and the three keys on the face of the control.

Step 1 To start programming, press the **SET** key once to access the Fahrenheit/Celsius mode. The display will show the current status, either **F** for degrees Fahrenheit or **C** for degrees Celsius. Then press either the up \uparrow or down \downarrow arrow key to toggle between the F or C designation

Stage 1

Step 2 Press the **SET** key again to access the stage 1 set point. The LCD will display the current set point and the **S1** annunciator will be blinking on and off to indicate that the control is in the set point mode. Then press either the up \uparrow key to increase or the down \downarrow key to decrease the set point to the desired temperature.

Step 3 Press the **SET** key again to access the stage 1 differential. The LCD will display the current differential and the **DIF1** annunciator will be blinking on and off to indicate that the control is in the differential mode. Then press either the up \uparrow key to increase or the down \downarrow key to decrease the differential to the desired setting.

Step 4 Press the **SET** key again to access the stage 1 cooling or heating mode. The LCD will display the current mode, either **C1** for cooling or **H1** for heating. Then press either the up \uparrow or down \downarrow key to toggle between the **C1** or **H1** designation.

Stage 2

Step 5 Press the **SET** key again to access the stage 2 set point. The LCD will display the current set point and the **S2** annunciator will be blinking on and off to indicate that the control is in the set point mode. Then press either the up \uparrow key to increase or the down \downarrow key to decrease the set point to the desired temperature.

Step 6 Press the **SET** key again to access the stage 2 differential. The LCD will display the current differential and the **DIF2** annunciator will be blinking on and off to indicate that the control is in the differential mode. Then press either the up \uparrow key to increase or the down \downarrow key to decrease the differential to the desired setting

Step 7 Press the **SET** key again to access the stage 2 cooling or heating mode. The LCD will display the current mode, either **C2** for cooling or **H2** for heating. Then press either the up \uparrow or down \downarrow key to toggle between the **C2** or **H2** designation. Press the **SET** key once more and programming is complete.

Refer to Page 3 for an illustrated guide to programming the HA30D.

NOTE: The HA30D will automatically end programming if no keys are depressed for a period of thirty seconds. Any settings that have been input to the control will be accepted at that point,

All control settings are retained in non-volatile memory if power to HA30D is interrupted for any reason. Re-programming is not necessary after power outages or disconnects unless different control settings are required.

Piping Diagrams

Use these Diagrams as a guide for proper connecting your manifolds to the Boiler Supply and Return

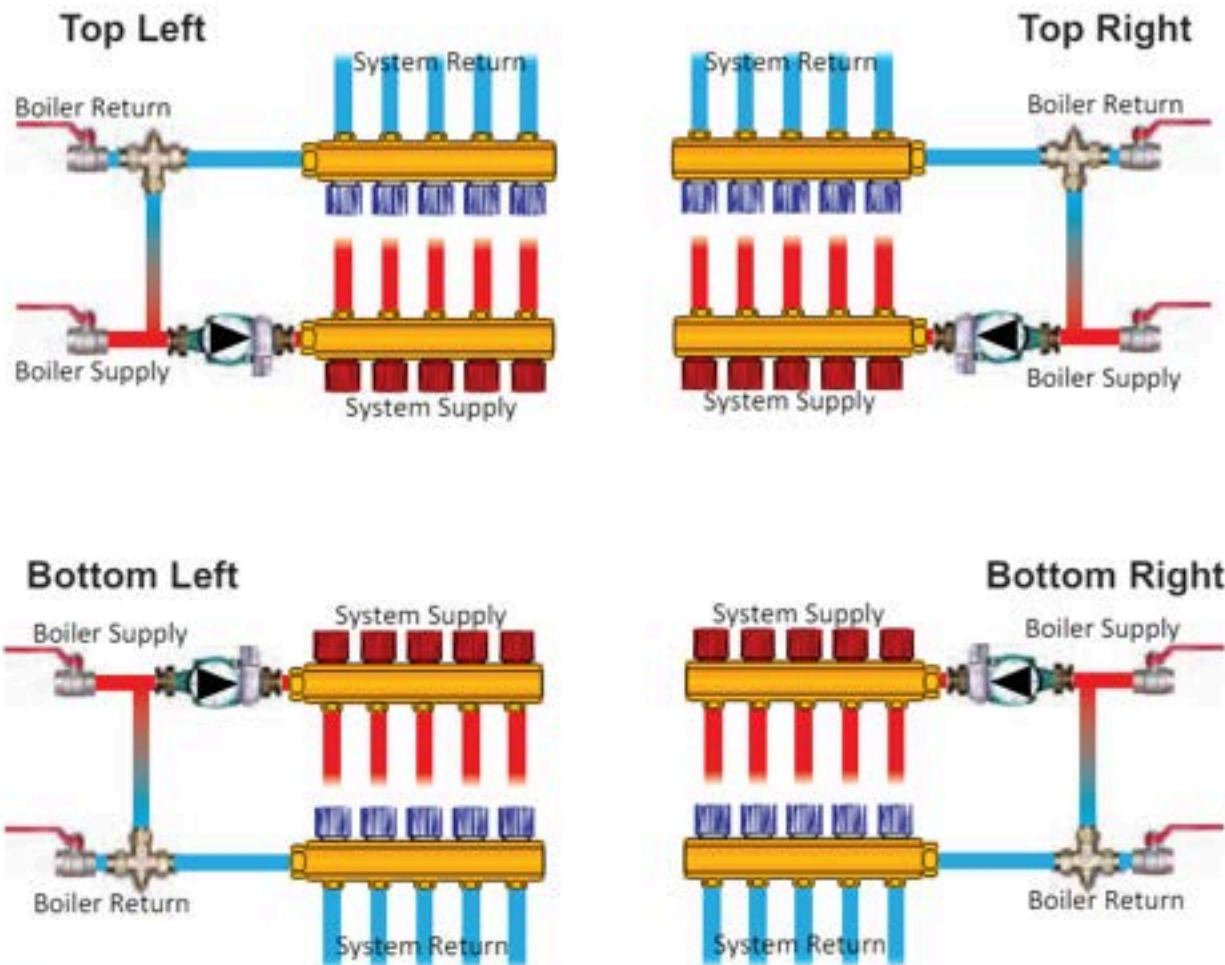

Note:

Caution should be made to limit the maximum water temperature delivered to the diverting valve to protect floors from excessive temperatures.

This is simply accomplished by installing an aquastat (M/H L6006 C series) that breaks on temperature rise and is wired in series with the circulator. Once the temperature limit is achieved the circulator stops. The temperature range should be from 14°F to 150°F (maximum).

Piping Diagrams

Piping with Multiple Zone Baseboard or Radiators, Single Circulator on System Supply

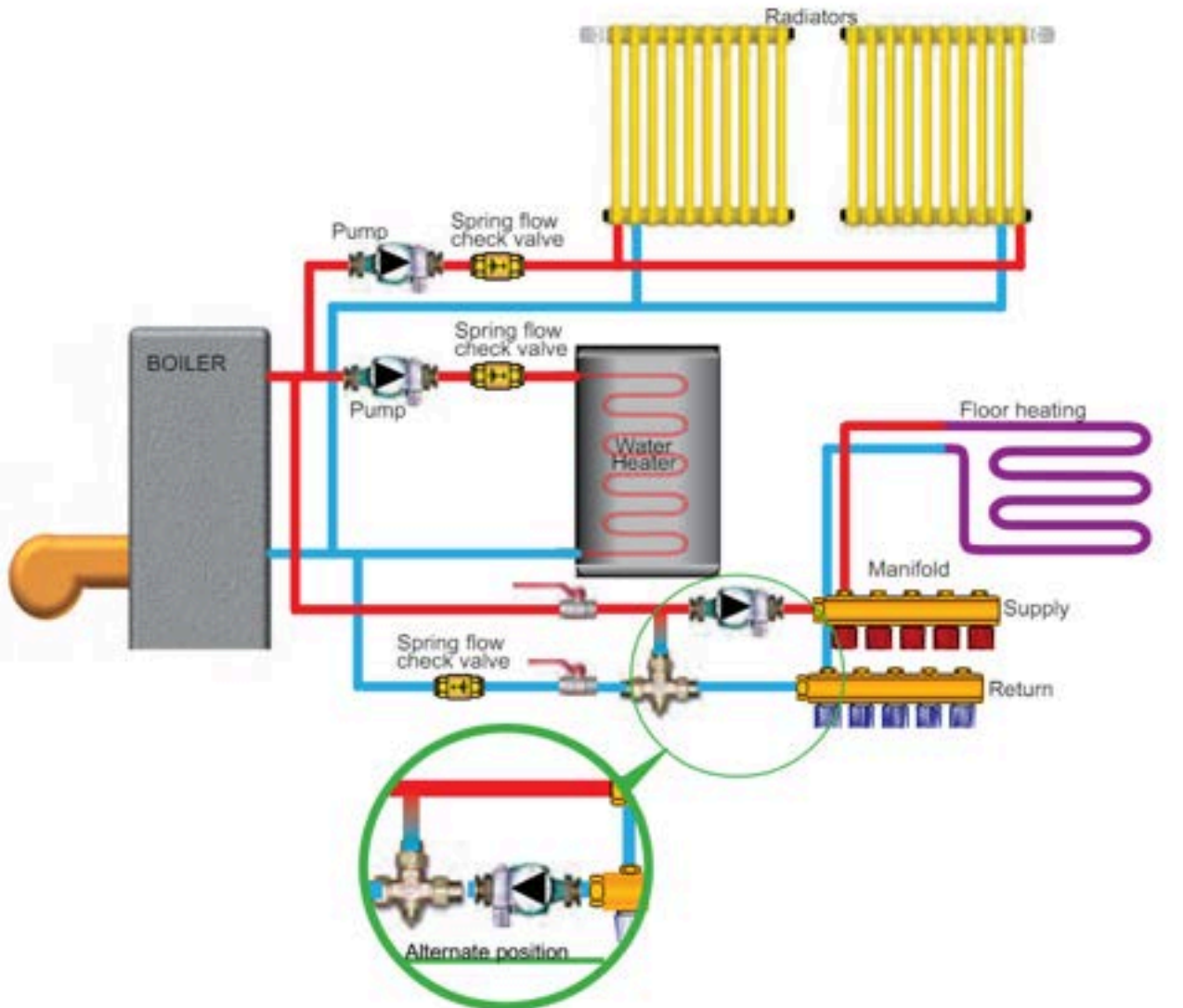

Piping with a Circulator Pump installed in the Boiler

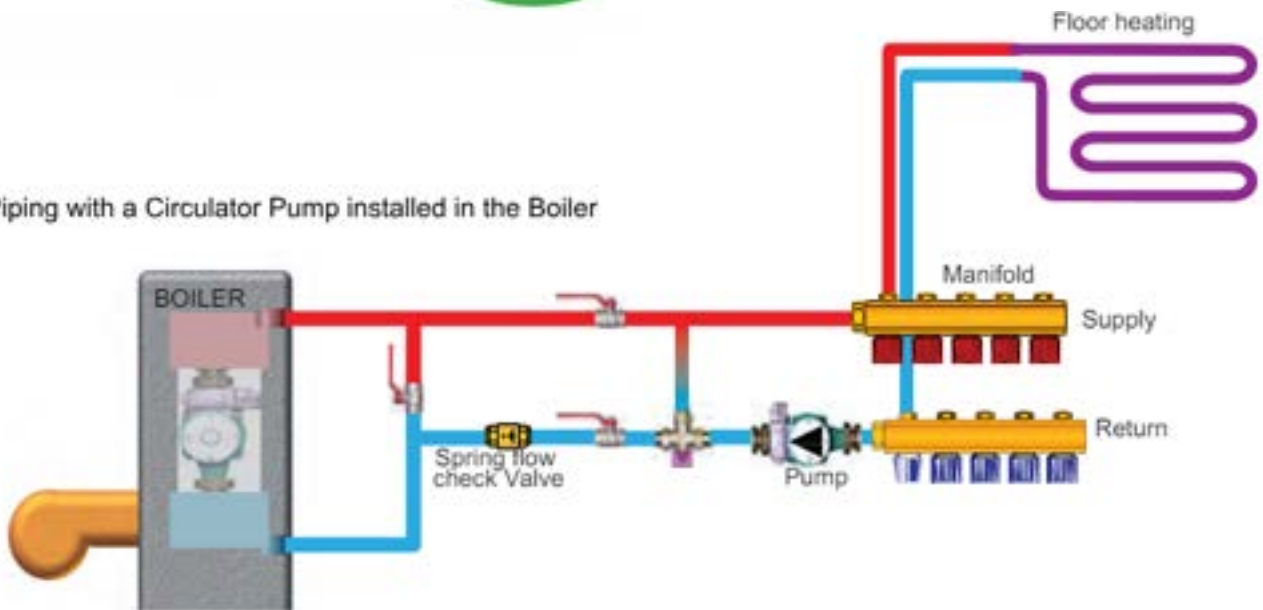

Base plate instructions

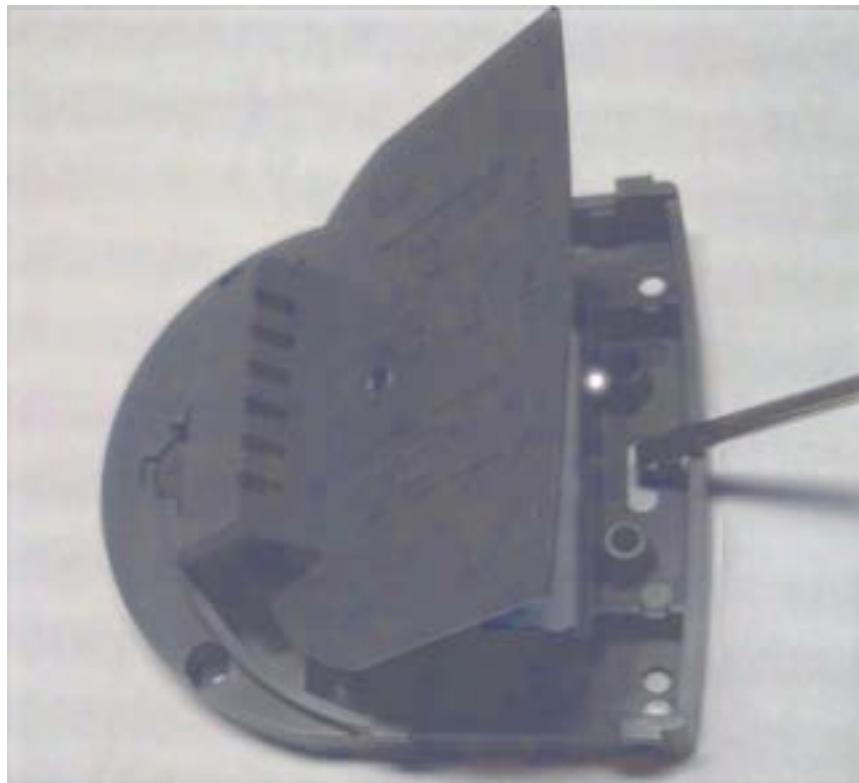
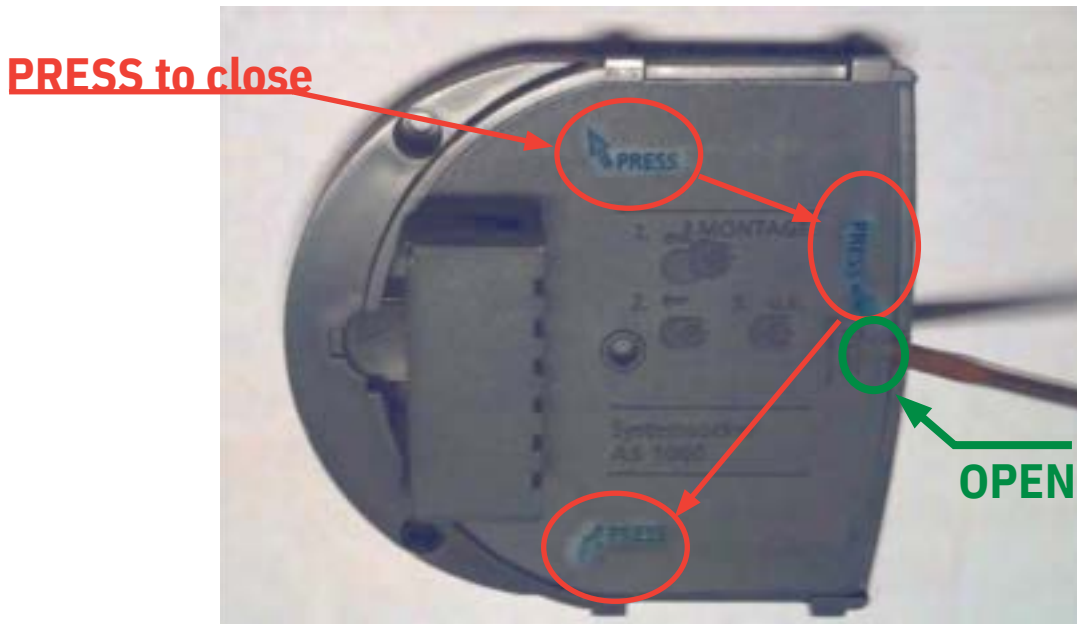

To open, insert a small screwdriver into the slot labelled "OPEN" and pry gently.
To close, push (3) places where it says "PRESS"