

1 inch Manifold

Applications:

Brass manifolds are provided for low temperature (radiant) or high temperature (radiation) hydronic heating systems. The 1 inch bar stock heating manifolds come with one galvanized steel mounting bracket for 2-port & 3-port manifolds and 2- steel mounting bracket for 4-port through 12-port manifolds.

Technical Data:

- 1" Brass header stock supply header is fitted with a black capped isolating globe valves which also act as a balancing valve. The return header is has an isolating valve with a white plastic cap which can receive an optional 24V powerheads for remote thermostat operation. The supply and return headers are furnished with 3/4" Euroconus insert connections to receive iron pipe (1/2" FIP only), copper (1/2" copper only) or plastic pipe compression fittings (3/16", 3/8", 1/2", 5/8", 3/4").
- Supply Manifold with balancing valves (black cap)
- Return Manifold with shut off valves (white cap)
- Mounting brackets
- 2- 3/4" Euroconus insert purge valves suitable to receive insert fittings (plastic pipe, female iron pipe 1/2" FIP or 1/2" copper). The drain valve cap also has shutoff key built in for easy on/off operation.
- 2-coin vents for air elimination and service.
- Red coin vent key which also operates S & R drain valve.
- Boiler/System Supply & Return connection 1" male iron pipe or 1" copper.
- Labels to identify runouts

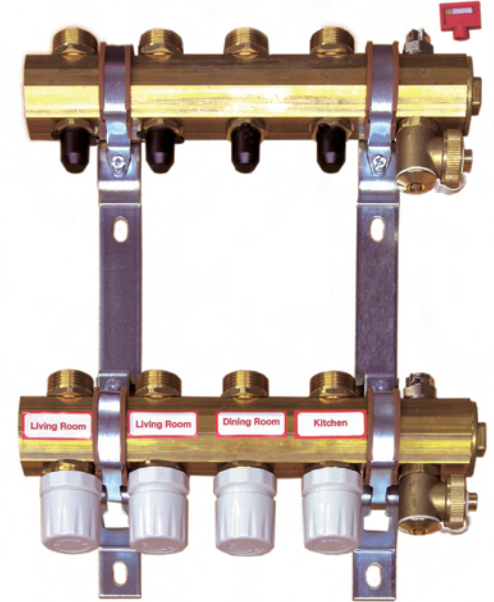

Installation:

Locate manifolds in strategic locations to minimize addition S & R runouts of your plastic heating pipes. It is always wise to use larger diameter supply and return mains reduce overall cost and keep your manifold size reasonable. If locating manifolds in sheetrock or plaster wall always install an access panel for serviceability.

Dimensions

n = number of outlets

n	inch	mm
2	6 1/2"	165
3	8 1/2"	215
4	10 3/8"	265
5	12 3/8"	315
6	14 3/8"	365
7	16 3/8"	415
8	18 1/4"	465
9	20 1/4"	515
10	22 1/4"	565
11	24 1/4"	615
12	26 1/8"	665

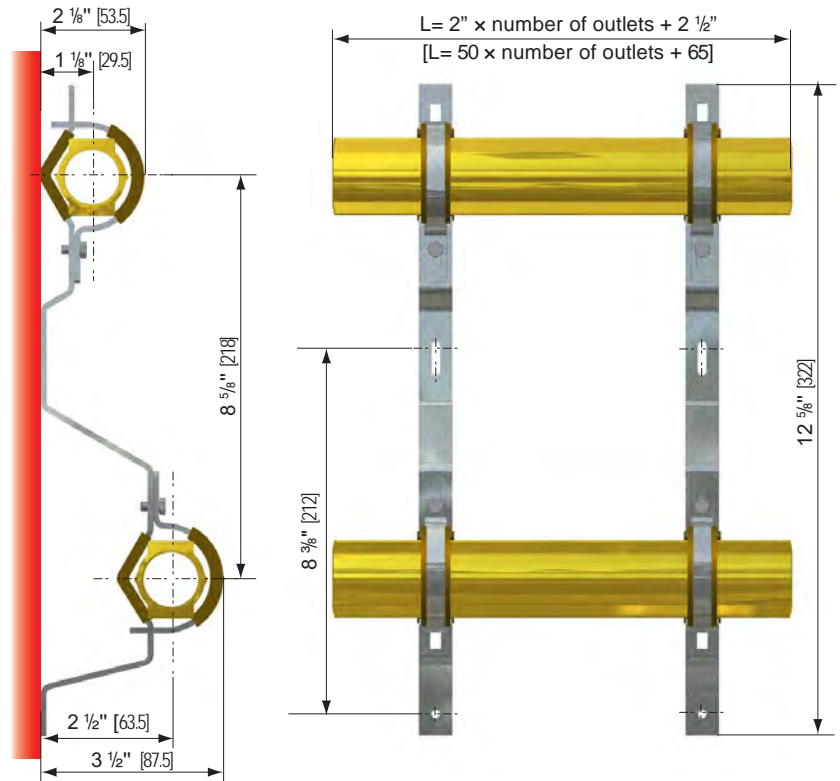

1 inch Manifold

Manifold configurations:

Manifolds can be built in any configuration-boiler supply left or right, or left and right for reverse return self balancing piping arrangement. Any possibility of top or bottom connection is possible for individual run outs.

Adjusting the balancing valves on the supply side of the manifold.

Using the red coin vent key close the valve covered by the black cap completely. Read the suggested balancing adjustment values from the scale. Turning the supply valve counterclockwise, open the valve with the appropriate number of rotations, turns; remove the coin vent key, put on the black cap back on.

- Balancing valves can also be installed in the return and the return valve cartridge on the supply.

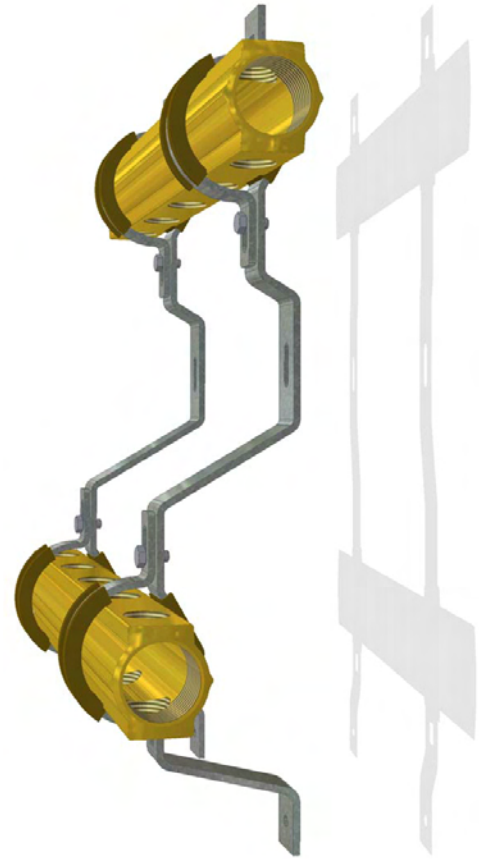

Manifold 1"

